



北京大学
PEKING UNIVERSITY

10010010

嵌入式系统编程与实践

3-嵌入式编程基础-接口

燕博南

2024秋

今天的第一个小任务

□分配开发板（每人一份，实名发放）

□注：学期末回收（除了互评第一）

□注：注意不要损坏

□分配实践课带班

接口无处不在

TSMC 28nm

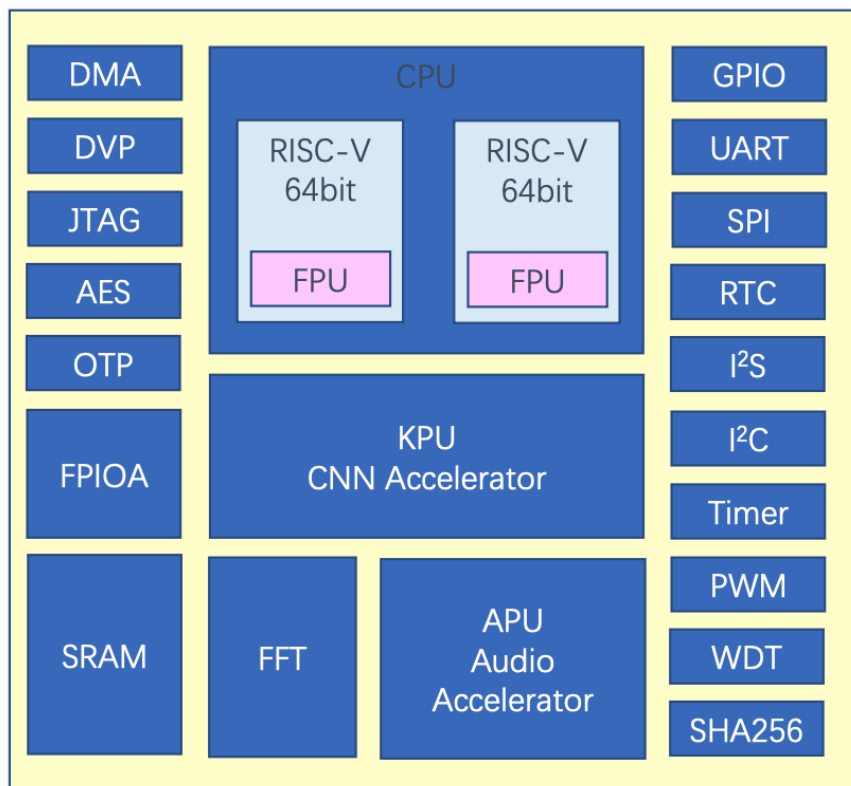

片间接口：

- UART
- SPI
- I²C

其他：

- PCIe
- DDR
- CXL
- UXL
- Ethernet

片内接口：

- AMBA接口
 - AXI
 - AHB
 - APB

UART-物理连接

- 物理接口

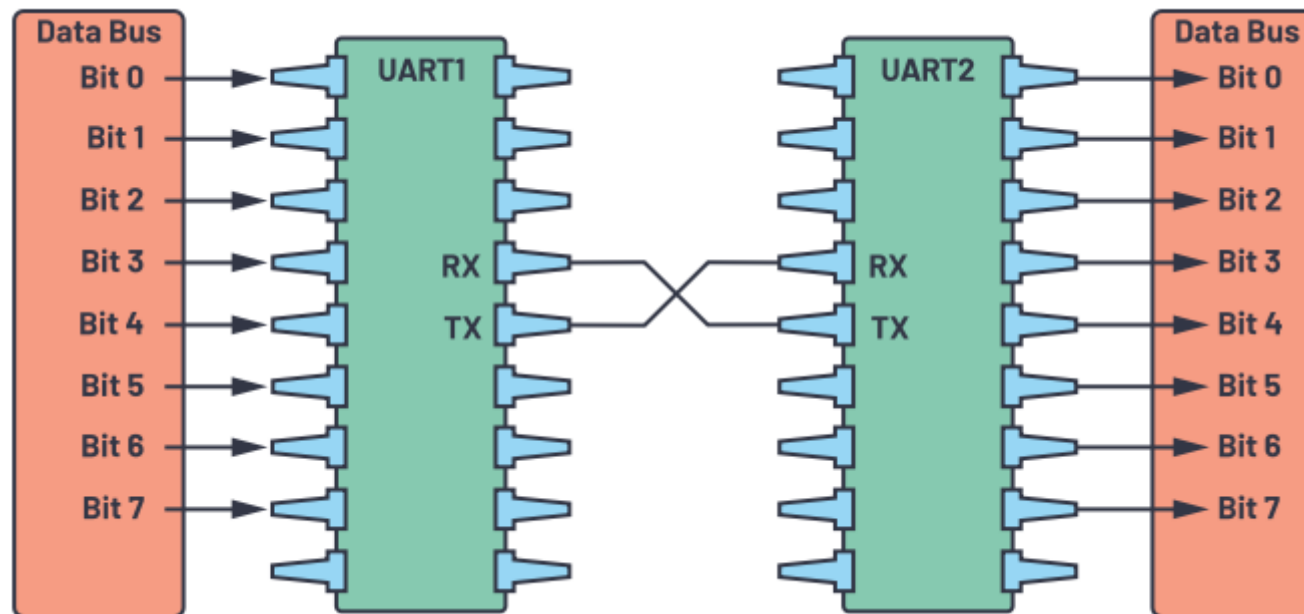
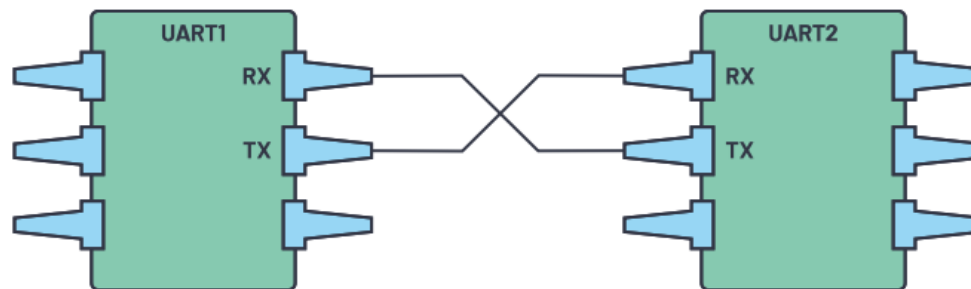

Time →

UART-物理接口

```
// Set Parameter CLKS_PER_BIT as follows:  
// CLKS_PER_BIT = (Frequency of  
i_Clock)/(Frequency of UART)  
// Example: 25 MHz Clock, 115200 baud UART  
// (25000000)/(115200) = 217
```

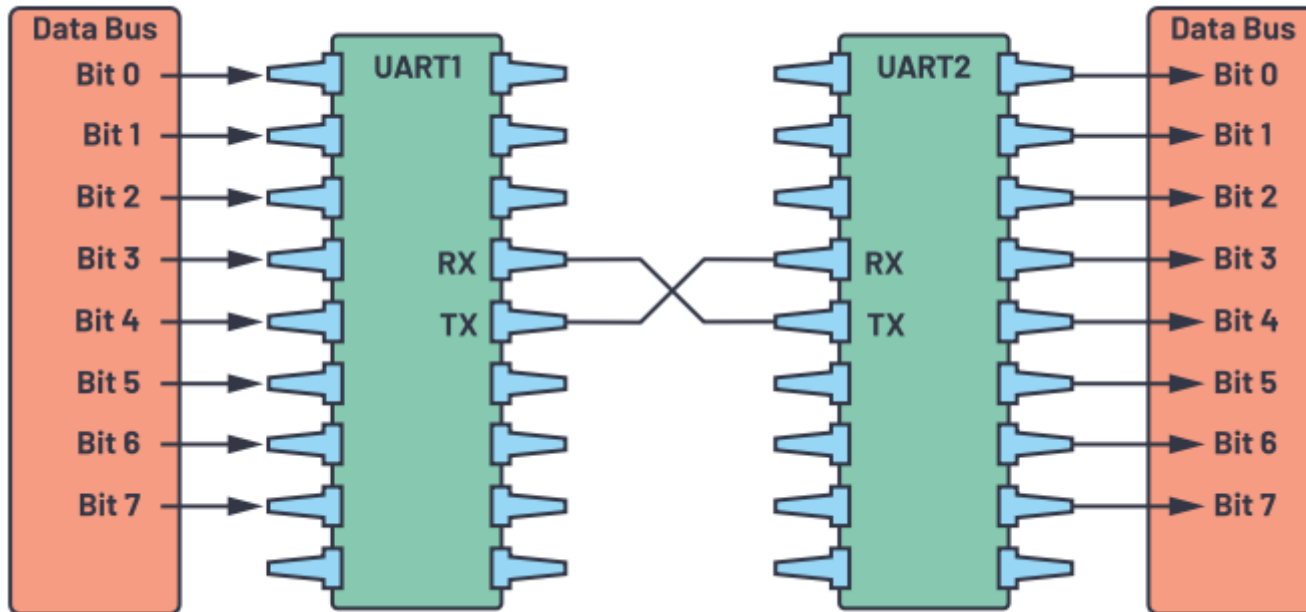

```
module UART_TX  
  #(parameter CLKS_PER_BIT = 217)  
  (  
    input          i_Rst_L,  
    input          i_Clock,  
    input          i_TX_DV,  
    input [7:0]    i_TX_Byte,  
    output reg     o_TX_Active,  
    output reg     o_TX_Serial,  
    output reg     o_TX_Done  
  );
```

```
module UART_RX  
  #(parameter CLKS_PER_BIT = 217)  
  (  
    input          i_Clock,  
    input          i_RX_Serial,  
    output         o_RX_DV,  
    output [7:0]  o_RX_Byte  
  );
```

UART-连接与编程 (FPGA to PC)

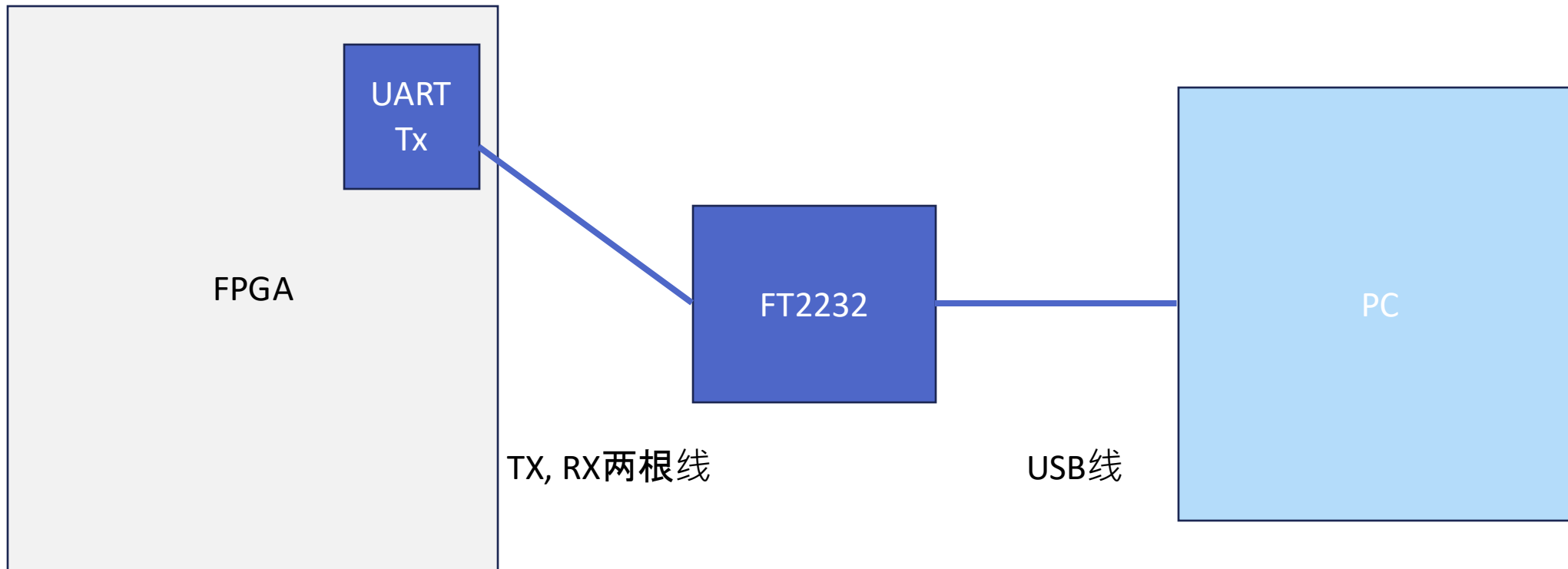

UART-连接与编程 (MCU to PC)

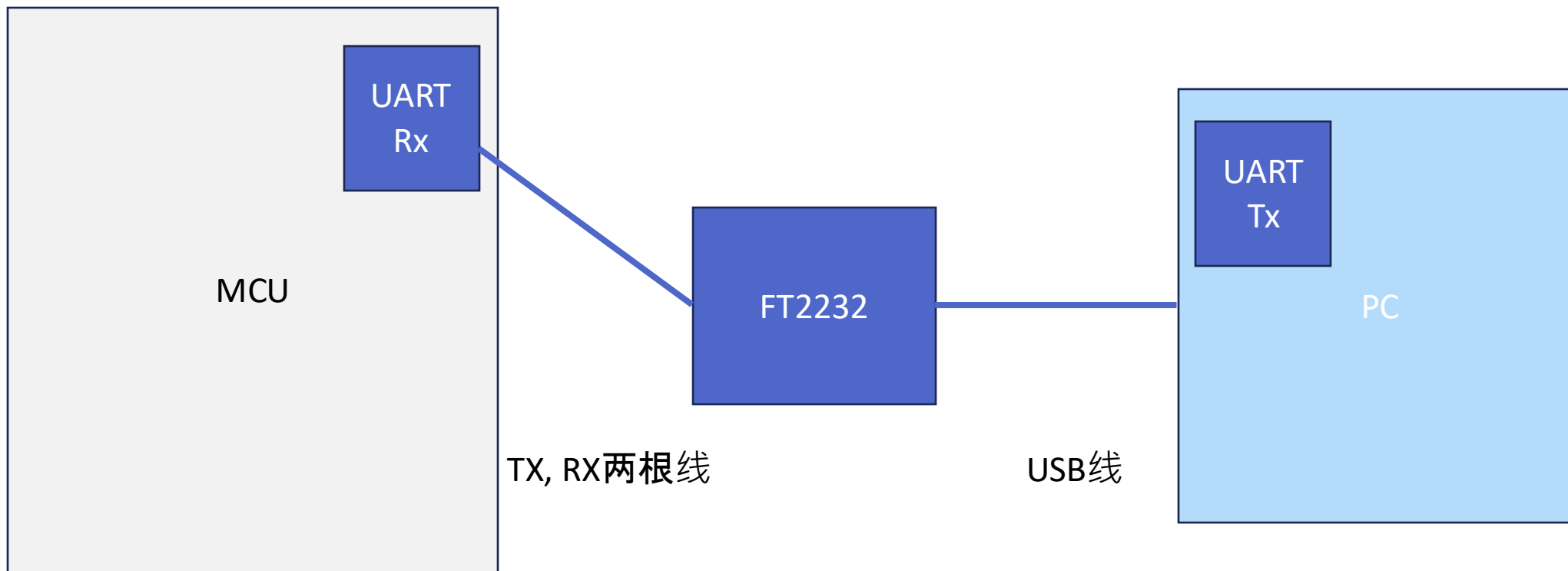

UART编程实例

- <https://github.com/kendryte/PaddlePi>
- PaddlePi / standalone-demos / uart

SPI

异步传输接口

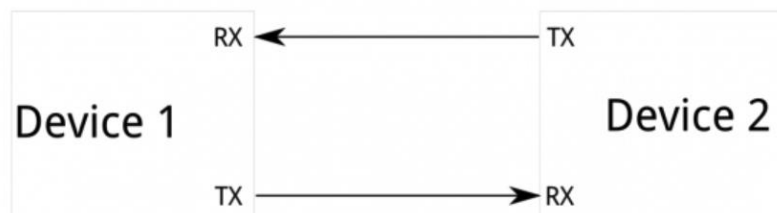

问题：

- 传输线没有公共的控制（异步）
- TX、RX的本地时钟必须差不多
- 一对一传输

改进版本

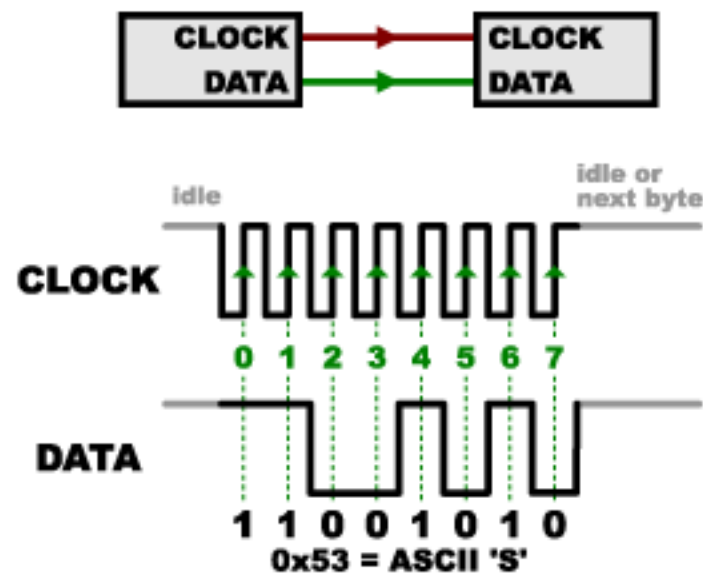
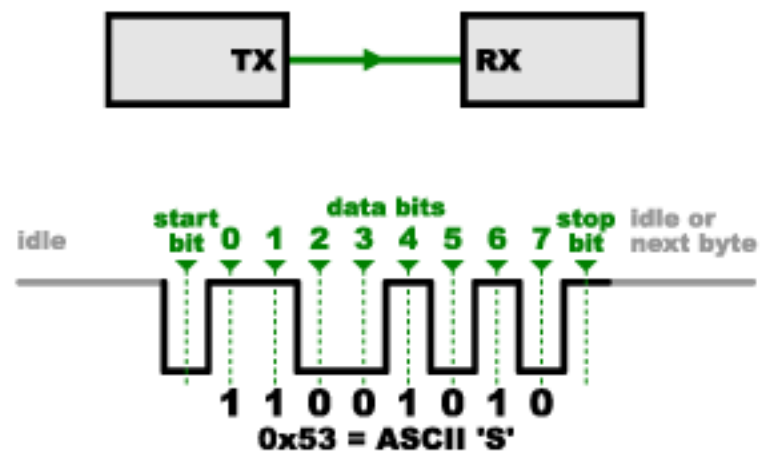

SPI - 一对一



Obsolete Name	Replacement Name
Master	Controller
Slave	Peripheral
MISO	POCI
MOSI	PICO
SS	CS

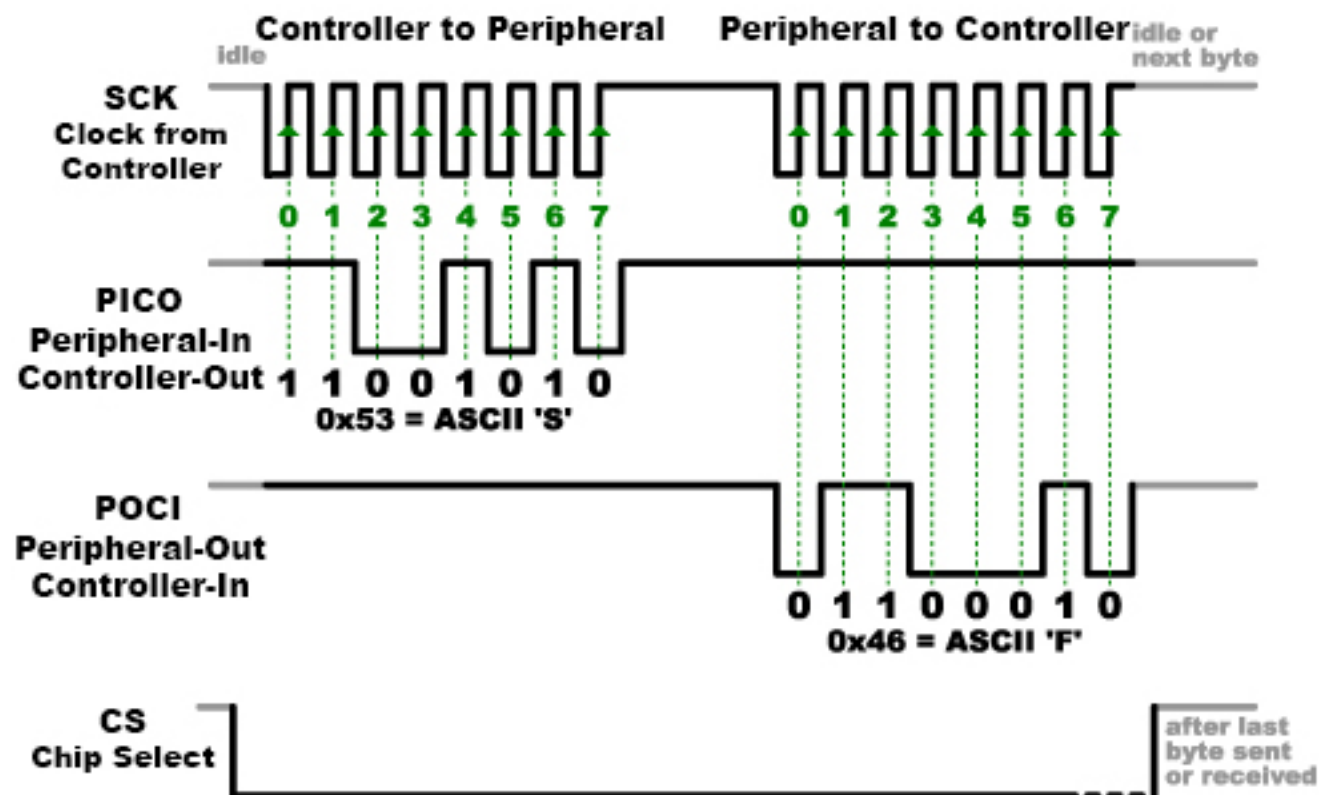

SPI – 一对多

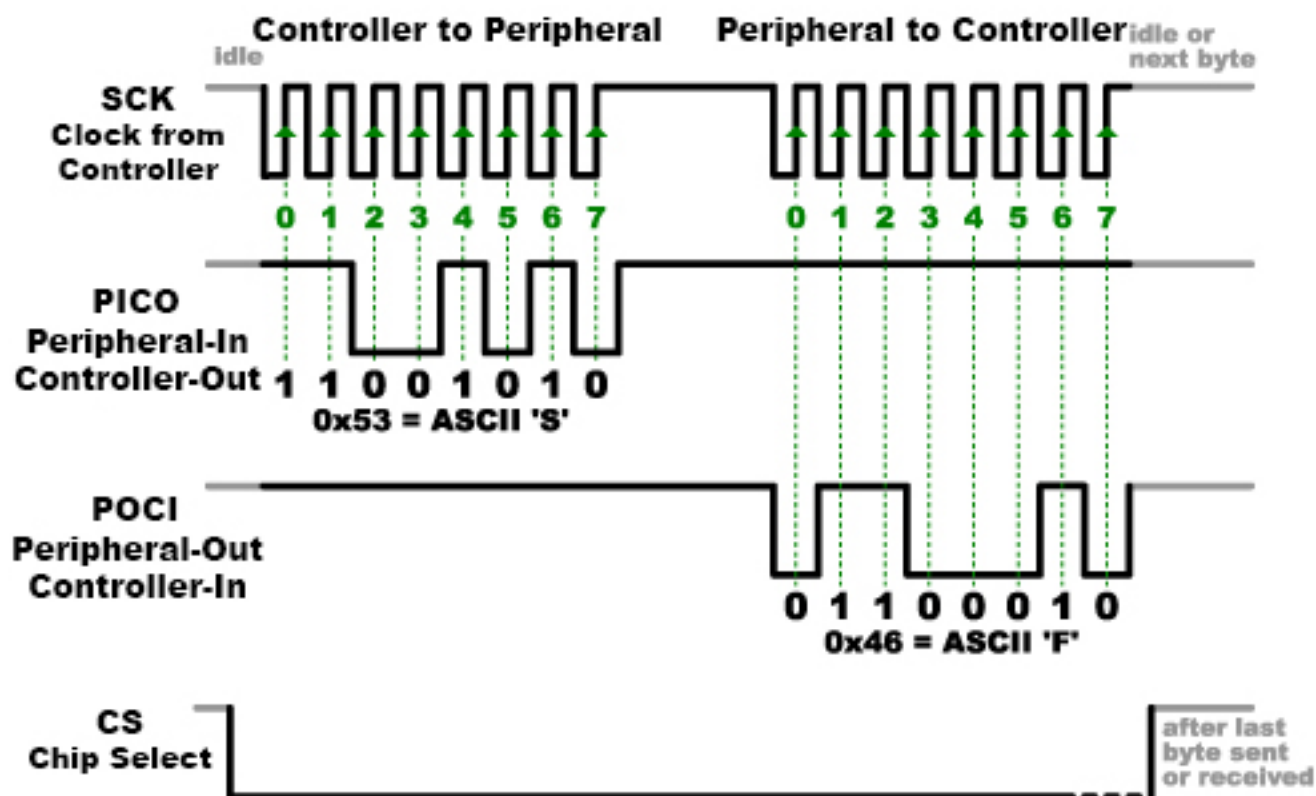
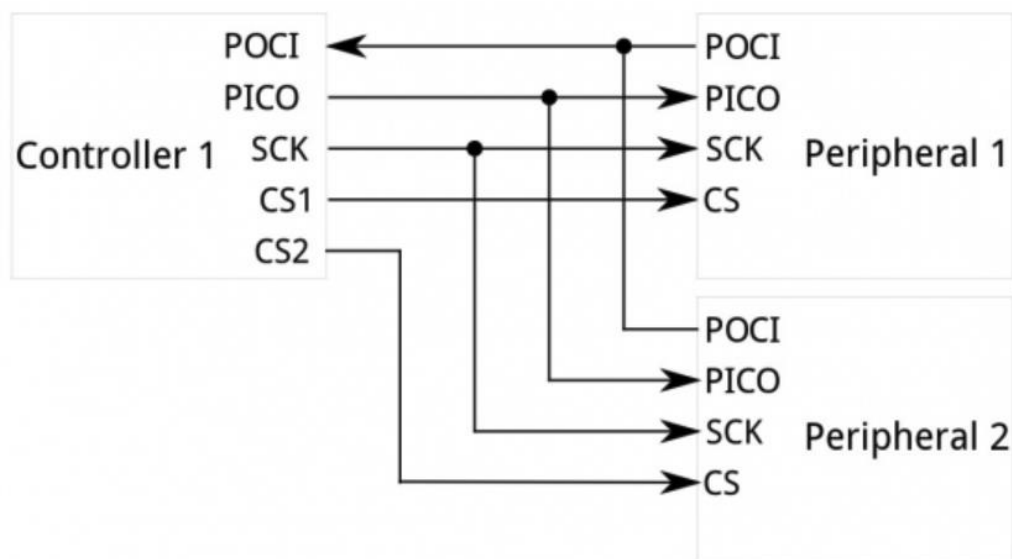

SPI - 一对多

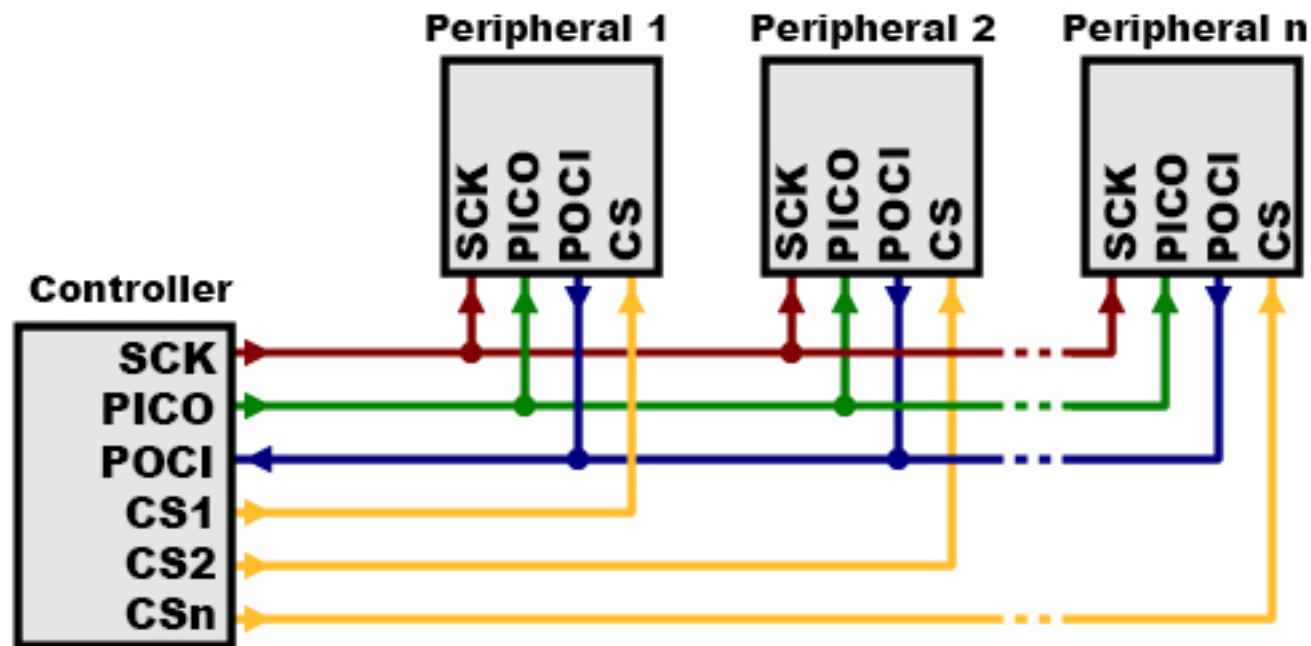
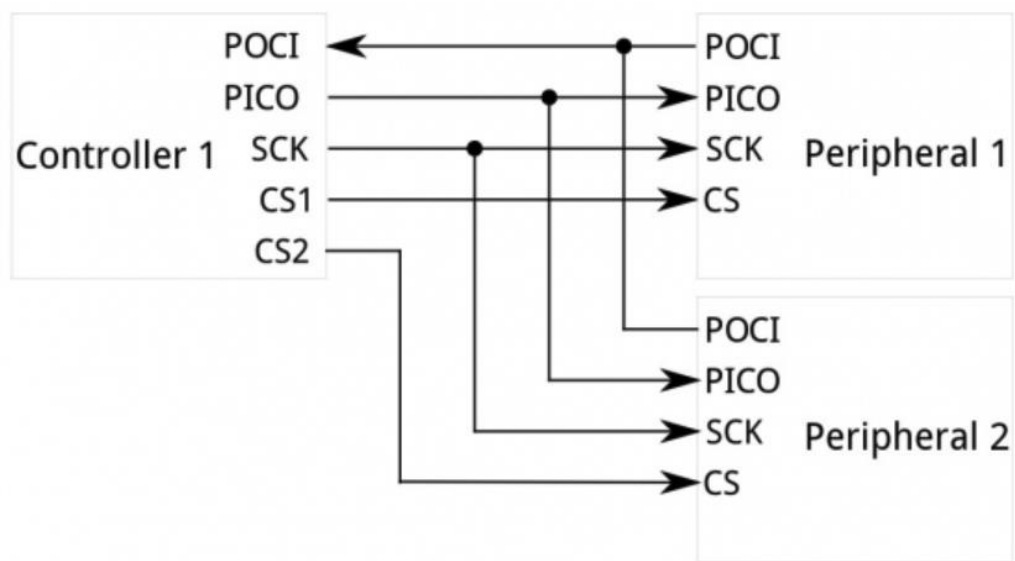

SPI – 一对多，但是daisy-chained

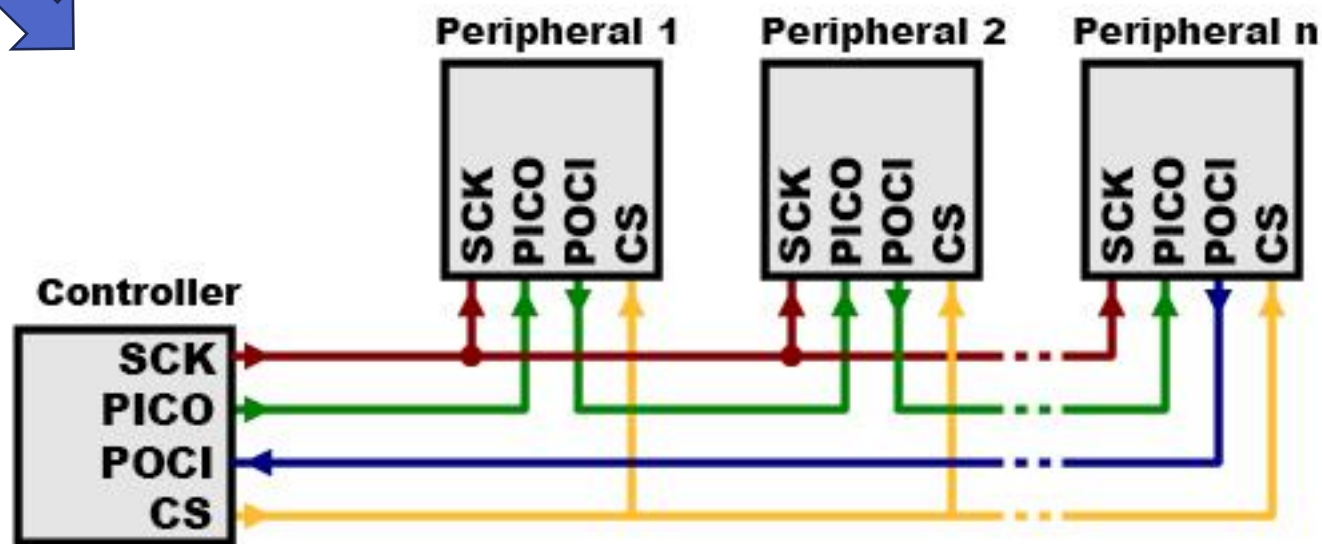
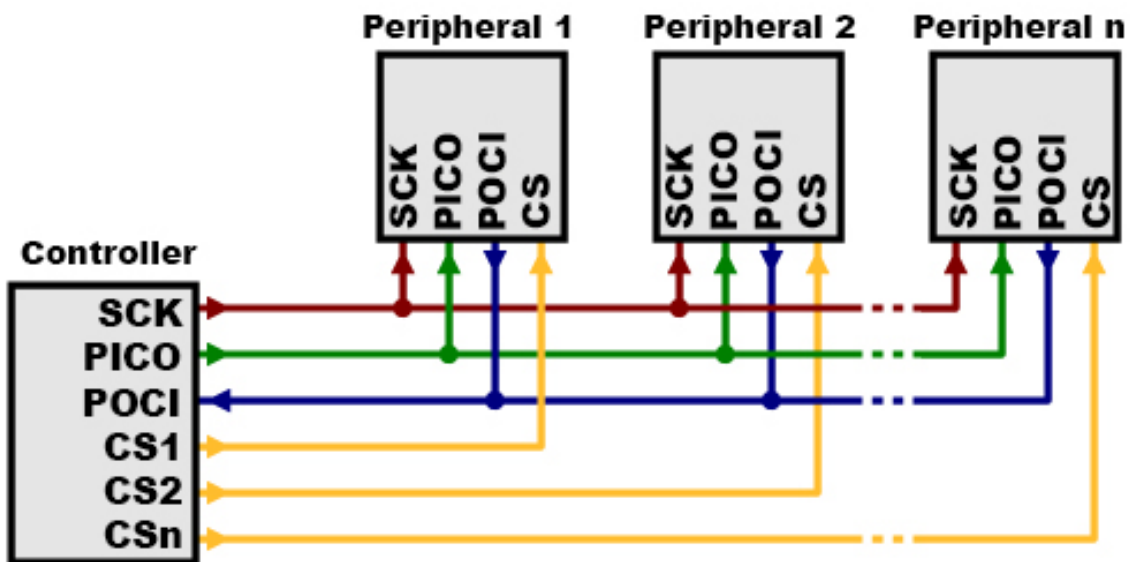

SPI Mode

SPI mode	Clock polarity (CPOL)	Clock phase (CPHA)	Data is shifted out on	Data is sampled on
0	0	0	falling SCLK, and when CS activates	rising SCLK
1	0	1	rising SCLK	falling SCLK
2	1	0	rising SCLK, and when CS activates	falling SCLK
3	1	1	falling SCLK	rising SCLK

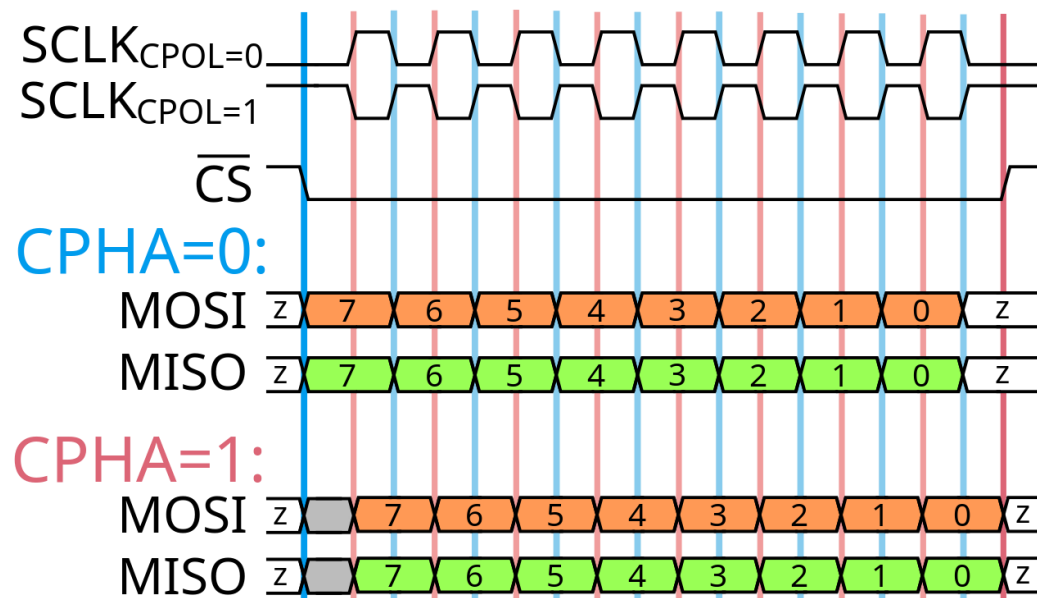

SPI编程

4_kendryte_standalone_programming_guide.pdf

16.3.1 spi_init

16.3.1.1 描述

设置 SPI 工作模式、多线模式和位宽。

16.3.1.2 函数原型

```
void spi_init(spi_device_num_t spi_num, spi_work_mode_t work_mode, spi_frame_format_t frame_format, size_t data_bit_length, uint32_t endian)
```

16.3.1.3 参数

参数名称	描述	输入输出
spi_num	SPI 号	输入
work_mode	极性相位的四种模式	输入
frame_format	多线模式	输入
data_bit_length	单次传输的数据的位宽	输入
endian	大小端 0: 小端 1: 大端	输入

16.3.3 spi_send_data_standard

16.3.3.1 描述

SPI 标准模式传输数据。

16.3.3.2 函数原型

```
void spi_send_data_standard(spi_device_num_t spi_num, spi_chip_select_t chip_select, const uint8_t *cmd_buff, size_t cmd_len, const uint8_t *tx_buff, size_t tx_len)
```

16.3.3.3 参数

参数名称	描述	输入输出
spi_num	SPI 号	输入
chip_select	片选信号	输入
cmd_buff	外设指令地址数据, 没有则设为 NULL	输入
cmd_len	外设指令地址数据长度, 没有则设为 0	输入
tx_buff	发送的数据	输入
tx_len	发送数据的长度	输入

16.3.3.4 返回值

无

16.3.5 spi_receive_data_standard

16.3.5.1 描述

标准模式下接收数据。

16.3.5.2 函数原型

```
void spi_receive_data_standard(spi_device_num_t spi_num, spi_chip_select_t chip_select, const uint8_t *cmd_buff, size_t cmd_len, uint8_t *rx_buff, size_t rx_len)
```

16.3.5.3 参数

参数名称	描述	输入输出
spi_num	SPI 号	输入
chip_select	片选信号	输入
cmd_buff	外设指令地址数据, 没有则设为 NULL	输入
cmd_len	外设指令地址数据长度, 没有则设为 0	输入
rx_buff	接收的数据	输出
rx_len	接收数据的长度	输入

16.3.5.4 返回值

无

QSPI : Quad serial peripheral interface

- 传输1组线变成4组线
- 共用1个SCK

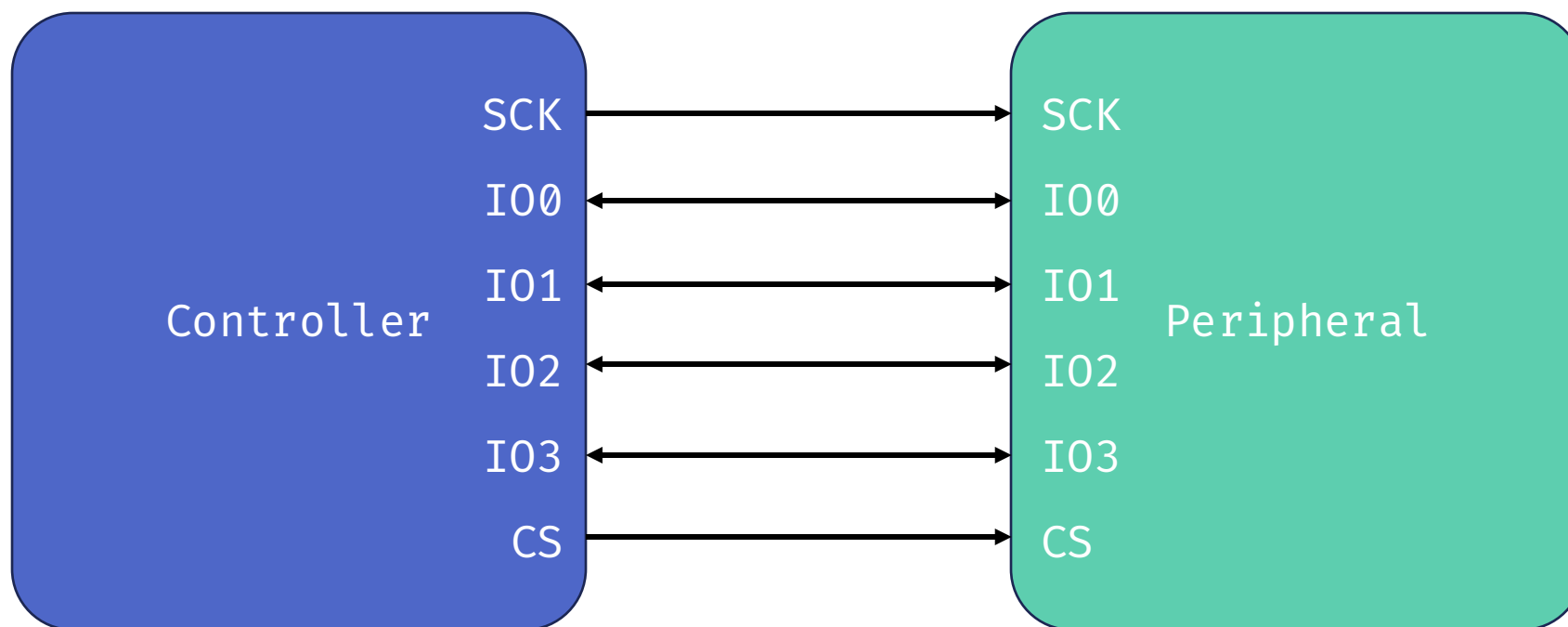

从 SPI 到 I²C

- SPI的特点：
- good for high data rate full-duplex (simultaneous sending and receiving of data) connections
- supporting clock rates upwards of 10MHz (and thus, 10 million bits per second) for some devices, and the speed scales nicely.
- The hardware at either end is usually a very simple shift register, allowing easy implementation in software.
- 但是！
 - SPI走线过多：每个interface 4根线

从 SPI 到 I²C

SPI

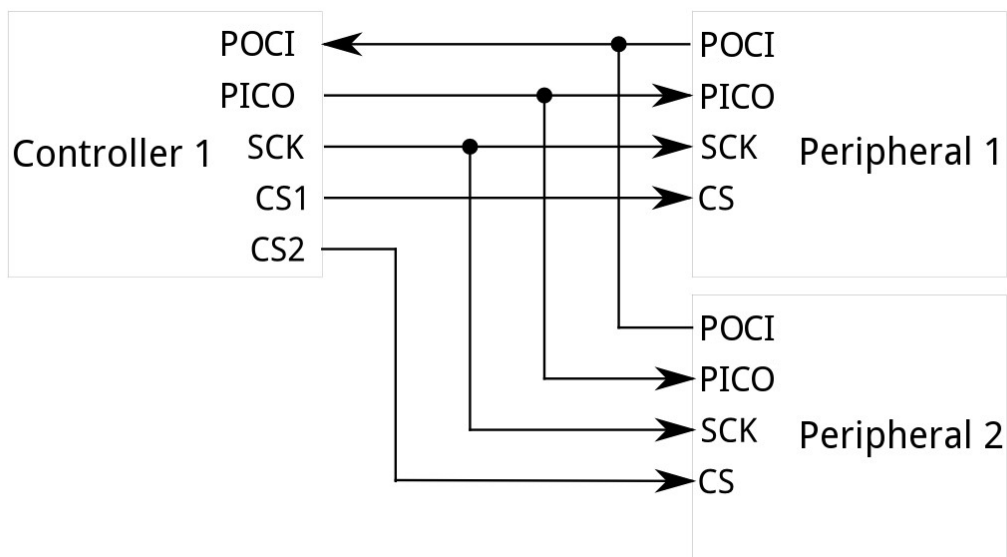

I²C

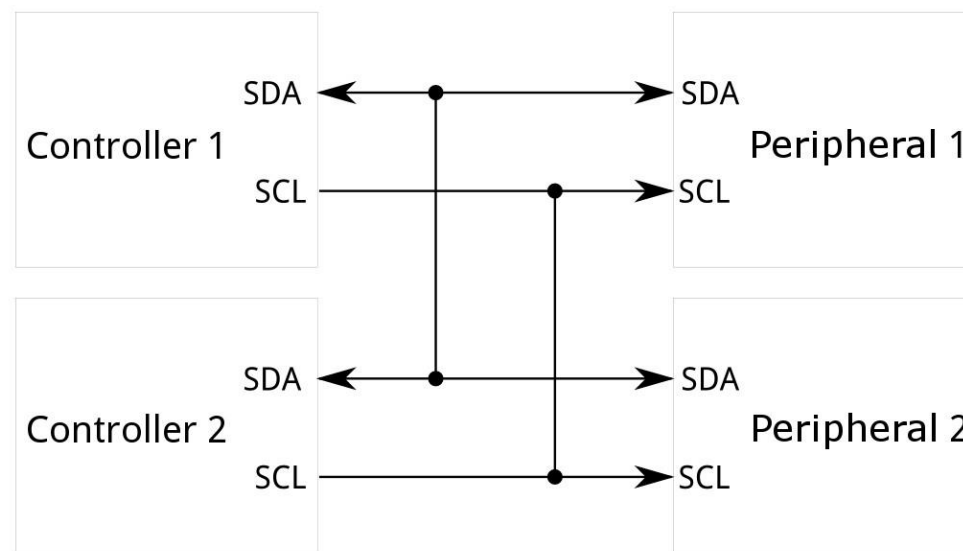

I²C Interface

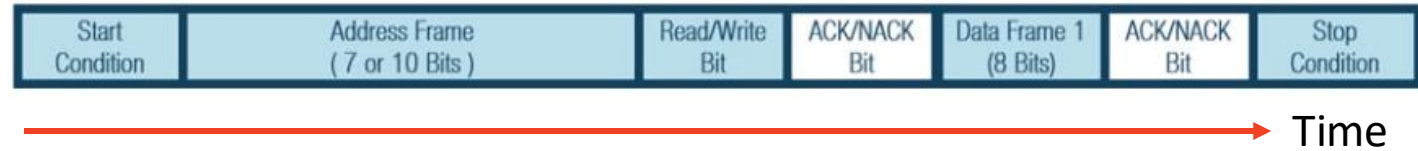
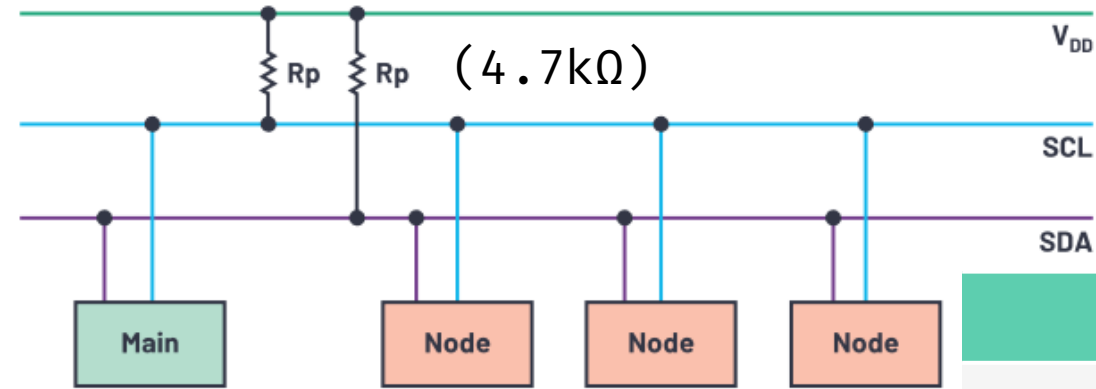

```

module I2C_main
(
    input      clk,
    input      rst,
    input [6:0] data_in,
    input [6:0] address,
    output     scl,
    inout     sda
);

```

Features	Specs
Wires	2
Maximum Speed	Standard mode = 100 kbps Fast mode = 400 kbps High speed mode = 3.4 Mbps Ultrafast mode = 5 Mbps
Synchronous or Asynchronous?	Synchronous
Serial or Parallel?	Serial
Maximum Number of Mains	Unlimited
Maximum Number of Nodes	1008

I²C Interface

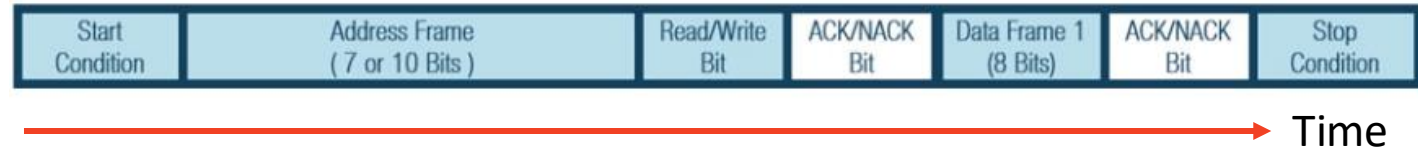
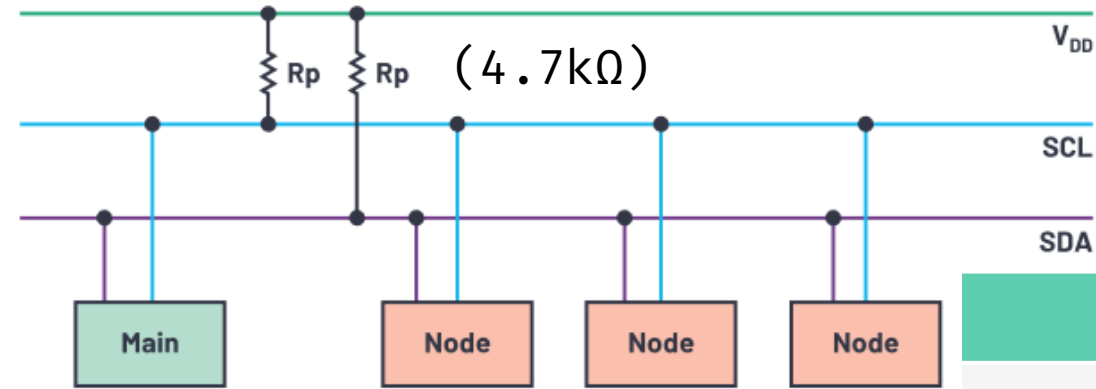

```

module I2C_node
(
    input      clk,
    input      rst,
    input      scl,
    inout     sda,
    output
);

```

Features	Specs
Wires	2
Maximum Speed	Standard mode = 100 kbps Fast mode = 400 kbps High speed mode = 3.4 Mbps Ultrafast mode = 5 Mbps
Synchronous or Asynchronous?	Synchronous
Serial or Parallel?	Serial
Maximum Number of Mains	Unlimited
Maximum Number of Nodes	1008

I²C 时序

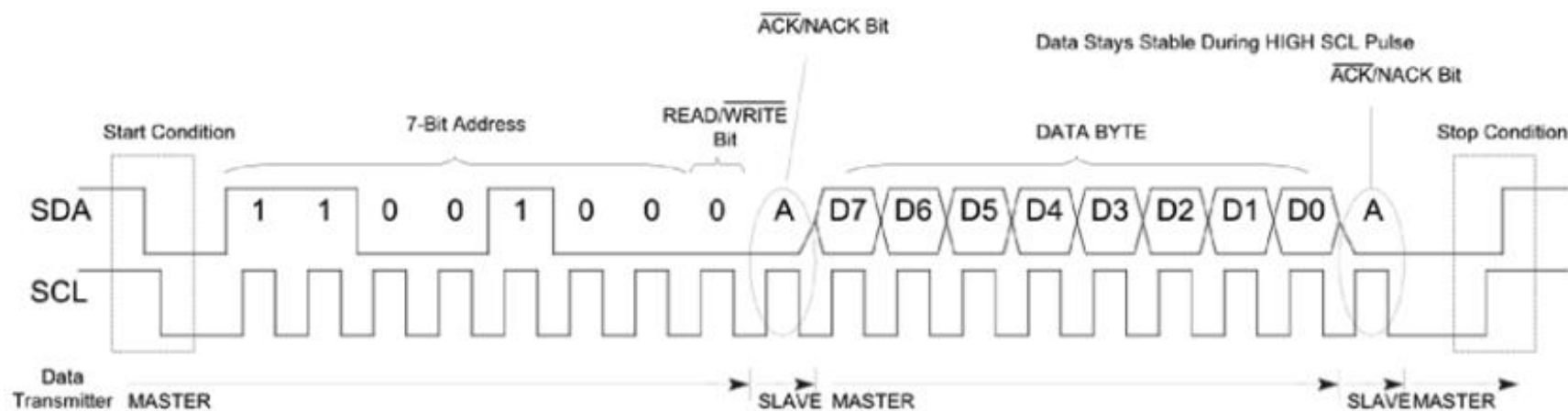

I²C-连接与编程

